



TIN CAN AUTOMOTIVE RECTIFIER

TR251 THRU TR254

VOLTAGE RANGE 100 to 400 Volts

CURRENT 25.0 Amperes

TECHNICAL SPECIFICATION:

FEATURES

- Low Leakage
- Low forward voltage drop
- High current capability
- High forward surge current capacity

MECHANICAL DATA

- Technology: vacuum soldered
- Case: Tin Can
- Polarity: the glass is blue (Positive)
the glass is white (Negative)
- Lead: Plated Ni lead, solderable per MIL-STD-202E method 208C
- Mounting: at will
- Weight: 0.09 ounces, 2.57 grams

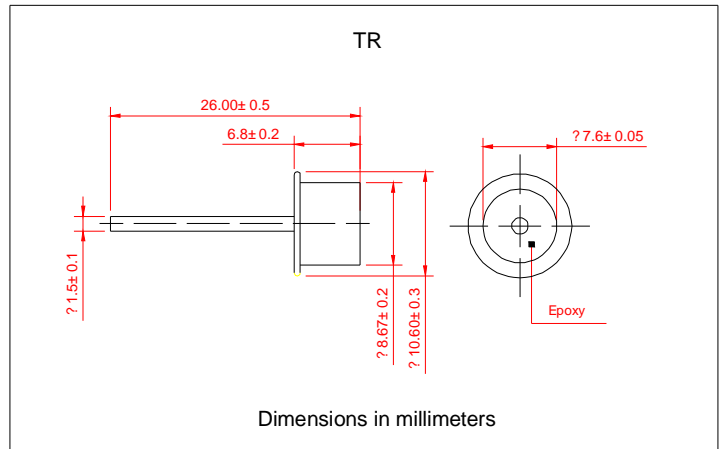

MAXIMUM RATINGS AND ELECTRICAL CHARACTERISTICS

- Ratings at 25°C ambient temperature unless otherwise specified
- Single Phase, half wave, 60HZ, resistive or inductive load
- For capacitive load derate current by 20%

	SYMBOLS	TR251	TR252	TR253	TR254	UNIT
Maximum Repetitive Peak Reverse Voltage	V_{RRM}	100	200	300	400	Volts
Maximum RMS Voltage	V_{RMS}	70	140	210	280	Volts
Maximum DC Blocking Voltage	V_{DC}	100	200	300	400	Volts
Maximum Average Forward Rectified Current, At $T_c=105^\circ\text{C}$	I_O	25				Amps
Peak Forward Surge Current 3.3ms single half sine wave superimposed on Rated load (JEDEC method)	I_{FSM}	400				Amps
Rating for fusing ($t < 8.3\text{ms}$)	I^2t	664				A^2S
Maximum instantaneous Forward Voltage at 100A	V_F	1.10				Volts
Maximum DC Reverse Current at Rated $T_A=25^\circ\text{C}$ DC Blocking Voltage $T_A=100^\circ\text{C}$	I_R	5.0				UA
		250				
Typical Thermal Resistance	$R_{\theta JC}$	1.0				$^\circ\text{C}/\text{W}$
Operating and Storage Temperature Range	T_J, T_{STG}	(-65 to +175)				$^\circ\text{C}$

Notes:

1. Enough heatsink must be considered in application.



TIN CAN AUTOMOTIVE RECTIFIER

TR251 THRU TR254

VOLTAGE RANGE 100 to 400 Volts

CURRENT 25.0 Amperes

RATINGS AND CHARACTERISTIC CURVES TR251 THRU TR254

F1G.1 TYPICAL FORWARD CURRENT DERATING CURVE

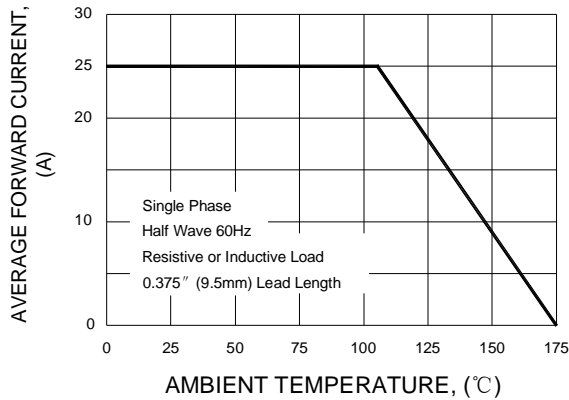

F1G.2 MAXIMUM NON-REPETITIVE PEAK FORWARD SURGE CURRENT

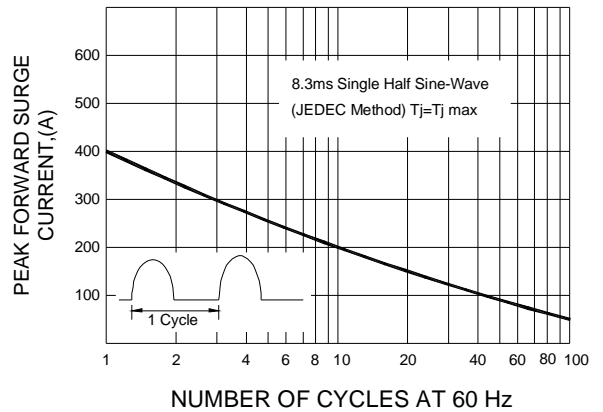

F1G.3 TYPICAL INSTANTANEOUS FORWARD CHARACTERISTICS

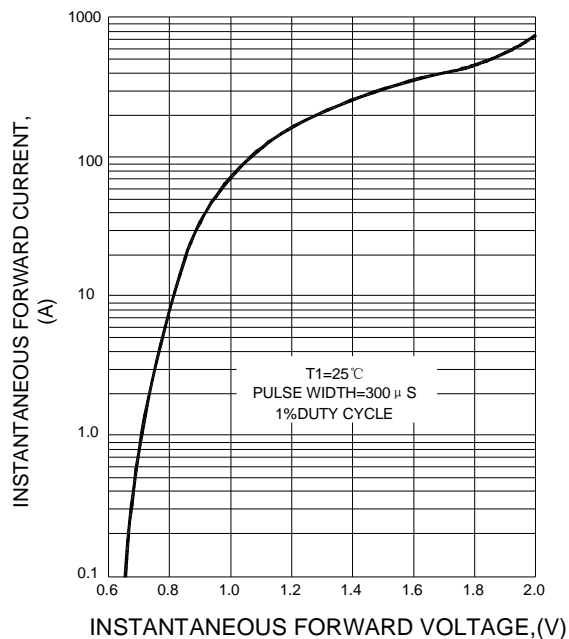

F1G.4 FORWARD POWER DISSIPATION

